

MODEL CUB5 - MINIATURE ELECTRONIC 8-DIGIT DUAL COUNTER & RATE INDICATOR



- LCD, POSITIVE REFLECTIVE OR NEGATIVE TRANSMISSIVE WITH YELLOW/GREEN OR RED LED BACKLIGHTING
- 0.46 INCH (11.7 mm) HIGH DIGITS
- PROGRAMMABLE DECIMAL POINT

- FRONT PANEL AND REMOTE RESET
- COUNT SPEEDS UP TO 20 KHz (High Speed Input)
- OPERATES FROM 9 to 28 VDC POWER SOURCE
- PROGRAMMABLE PRESCALER FOR TOTALING
- BI-DIRECTIONAL COUNTING, UP/DOWN CONTROL
- QUADRATURE SENSING (Up to 4 Times Resolution)
- ANTI-COINCIDENCE COUNTING (ADD/ADD & ADD/SUB)
- SEPARATE COUNT AND RATE INPUT MODE
- WIRE CONNECTIONS MADE VIA SCREW CLAMP TYPE TERMINALS
- DUAL COUNTER MODE
- COUNT INPUT VOLTAGE UP TO +28 VDC
- NEMA 4X/IP65 SEALED FRONT BEZEL



DESCRIPTION

The CUB5 provides up to three functions in a single display package (rate indicator and two counters). The display can be toggled either manually or automatically between the rate and counter(s) display.

The CUB5 display has 0.46" (11.7 mm) high digits. The LCD display is available in Positive Image Reflective (CUB50000), Negative Image-Transmissive with yellow/green backlighting (CUB50010), or Negative Image-Transmissive with red backlighting (CUB50020).

The counters may be programmed for one of eight different count modes. The counters and rate indicator have separate scaling and decimal point placement for read-outs in different engineering units.

Input A accepts a signal for the Count and Rate displays. Input B accepts a signal for the Count display or direction control. In the anti-coincidence mode, both inputs are monitored simultaneously so that no counts are lost. The final count can be chosen as the sum or difference of the two inputs. The Rate Indicator has programmable low (minimum) and high (maximum) update times to provide optimal display response at any input frequency. There is a programmable user input that can be set for one of a variety of functions.

The unit is housed in a lightweight, high-impact plastic case with a clear viewing window. The sealed front panel meets NEMA 4X/IP65 specifications for wash-down and/or dusty environments, when properly installed.

The CUB5 can be powered from an optional RLC Micro Line/Sensor Power Supply (MLPS0000) attached directly to the rear of a CUB5. The MLPS0000 is powered from either a 115 or 230 VAC source.

SAFETY SUMMARY

All safety related regulations, local codes and instructions that appear in the manual or on equipment must be observed to ensure personal safety and to prevent damage to either the instrument or equipment connected to it. If equipment is used in a manner not specified by the manufacturer, the protection provided by the equipment may be impaired.

SPECIFICATIONS

- DISPLAY:** 8 digit LCD 0.46" (11.7 mm) high digits
 Transmissive red or yellow/green backlight, or Reflective. The viewing angle of a transmissive display is designed for viewing at eye level or above the display. Reflective display units have a full viewing angle.
- POWER REQUIREMENTS:**
Reflective Versions: 9 to 28 VDC @ 15 mA max.
Backlight Versions: 9 to 28 VDC @ 60 mA max.
 Above 24 VDC, derate operating temperature to 50°C.
 Must use an RLC model MLPS or a Class 2 or SELV rated power supply.
- MEMORY:** Nonvolatile E²PROM memory retains all programming parameters and the count value when power is removed.
- USER INPUT:** Programmable, connect to common to activate function.
Threshold Levels: V_{IH} = 4.2 V min, V_{IL} = 0.5 V max, V_{MAX} = 28 VDC.
Response Time: 50 msec for Inhibit function, 100 msec for all others.
Current Sinking: Internal 40 KΩ typical. Pull-up to +5 V.
Current Sourcing: External pull-down resistor required, 2KΩ max.
- INPUTS A and B:**
Trigger Levels: V_{IH} = 4.2 V min, V_{IL} = 0.5 V max, V_{MAX} = 28 VDC.
Max Input Frequency: 20 KHz, 50% duty cycle.
Current Sinking: Internal 40 KΩ typical. Pulled-up to +5 V.
Current Sourcing: External pull-down resistor required, 2 KΩ max.
Filter A and B: Limits Input signal to a max. frequency of 100 Hz. Connect to common to activate.



CAUTION: Read complete instructions prior to installation and operation of the unit.



CAUTION: Risk of electric shock.

DIMENSIONS In inches (mm)

Note: Recommended minimum clearance (behind the panel) for mounting clip installation is 2.15" (54.6) H x 3.00" (76.2) W.

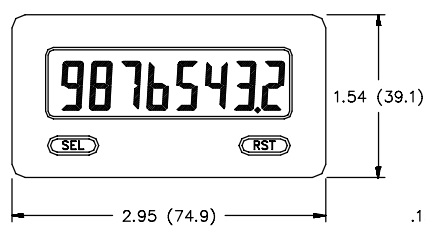

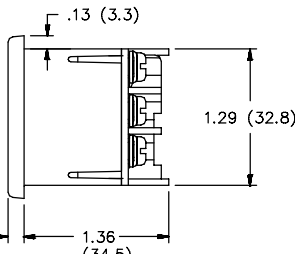

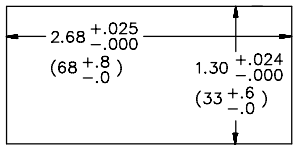

PANEL CUT-OUT

SPECIFICATIONS (Cont'd)

6. FRONT PANEL BUTTONS:

SELECT: Toggles display in the normal operating mode if enabled. Advances menu selection in programming mode.

RESET: Resets counter to zero in the normal operating mode if enabled. Changes data in programming mode.

7. **COUNT DISPLAY:** 8-digit with positive count, 7-digit with minus sign indication for negative count and the display flashes "tot OVer" for an overflow condition. Dual count mode only, "B" counter, seven digit positive count: "btot OVer" appears for an overflow condition.

8. **RATE DISPLAY:** 6 digits with an annunciator "R" on the left hand side of the LCD.

Overflow Indication: "R OLOLOL" appears when max. display digits are exceeded.

9. **RATE ACCURACY:** 0.05%

10. **RATE MINIMUM INPUT FREQUENCY:** 0.01 KHz

11. **RATE MAXIMUM FREQUENCY:** 10 KHz

12. MAXIMUM COUNT RATES:

COUNTER MODE	RATE ENABLED	RATE DISABLED
cnt ud	10 KHz	20 KHz
rtE cnt	7.5 KHz	20 KHz
QUAd1	5 KHz	10 KHz
QUAd2	5 KHz	8 KHz
QUAd4	2.5 KHz	5 KHz
Add Add	7.5 KHz	10 KHz
Add Sub	7.5 KHz	10 KHz
dUAL cnt	7.5 KHz	10 KHz

13. ENVIRONMENTAL CONDITIONS:

Operating Temperature: 0 to 60°C (above 50°C, derate backlight operating voltage to 24 VDC max.).

Storage Temperature: -30 to 85°C

Operating and Storage Humidity: 85% max. (non-condensing) from 0°C to 50°C.

Altitude: Up to 2000 meters

14. CERTIFICATIONS AND COMPLIANCES:

SAFETY

IEC 1010-1, EN 61010-1: Safety requirements for electrical equipment for measurement, control, and laboratory use, Part 1.

IP65 Enclosure rating (Face only), IEC 529

Type 4X Enclosure Rating (Face only), UL50

ELECTROMAGNETIC COMPATIBILITY

Immunity to EN 50082-2

Test	Standard	Level
Electrostatic discharge	EN 61000-4-2	Level 2; 4 Kv contact Level 3; 8 Kv air
Electromagnetic RF fields	EN 61000-4-3	Level 3; 10 V/m ¹ 80 MHz - 1 GHz
Fast transients (burst)	EN 61000-4-4	Level 4; 2 Kv I/O Level 3; 2 Kv power
RF conducted interference	EN 61000-4-6	Level 3; 10 V/rms 150 KHz - 80 MHz
Simulation of cordless telephone	ENV 50204	Level 3; 10 V/m 900 MHz ± 5 MHz 200 Hz, 50% duty cycle

Emissions to EN 50081-2

Test	Standard	Class
RF interference	EN 55011	Enclosure class A Power mains class A

Refer to EMC Installation Guidelines for additional information.

15. **CONSTRUCTION:** High impact plastic case with clear viewing window.

The front panel meets NEMA 4X/IP65 requirements for indoor use when properly installed. Installation Category I, Pollution Degree 2. Panel gasket and mounting clip included.

16. **WEIGHT:** 3 oz (85 grams)

BASIC OPERATION

When power is applied to the unit, it performs an internal self-diagnostic test and then the unit displays its revision level. If all P's appear in the display, press the select (SEL) button and check all of the data setups.

The CUB5 can be programmed to function as a single counter, dual counters, single counter with rate indication or dual counters with rate indication.

Counter

The CUB5 receives incoming pulses and multiplies them by the Count Scale Factor. The unit's counter (internal count value) keeps track of the scaled input pulse count which results in the desired reading value for the count display. Input A accepts the signal for the count and Input B is used for quadrature, dual counter, anti-coincidence counting, or up/down control counting.

The count(s) reset to zero when a manual reset is performed. At loss of power to the unit, the contents of the counter are saved. This allows counting over consecutive shifts, days, etc. The total count can accumulate to 99,999,999. The "B" counter, if enabled, can accumulate 9,999,999 counts.

Note: The counter value will roll over and flash "tot OVer" when the count value exceeds 99,999,999, indicating an overflow condition. The "B" counter, if enabled, will roll over and flash "btot OVer" when the count exceeds 9,999,999.

Rate

The signal at Input A is for the Rate indicator, which uses a time interval method (1/tau) to calculate the rate value. The unit counts on the negative edge of the input pulses. After the programmed minimum update time elapses and the next negative edge occurs, the unit counts the number of edges that occurred during the elapsed time. The number of edges is multiplied by the rate scaling value to calculate the rate value. At slower rates, averaging can be accomplished by programming the rate minimum update time for the desired response. Extensive scaling capabilities allow practically any desired reading at very slow count rates.

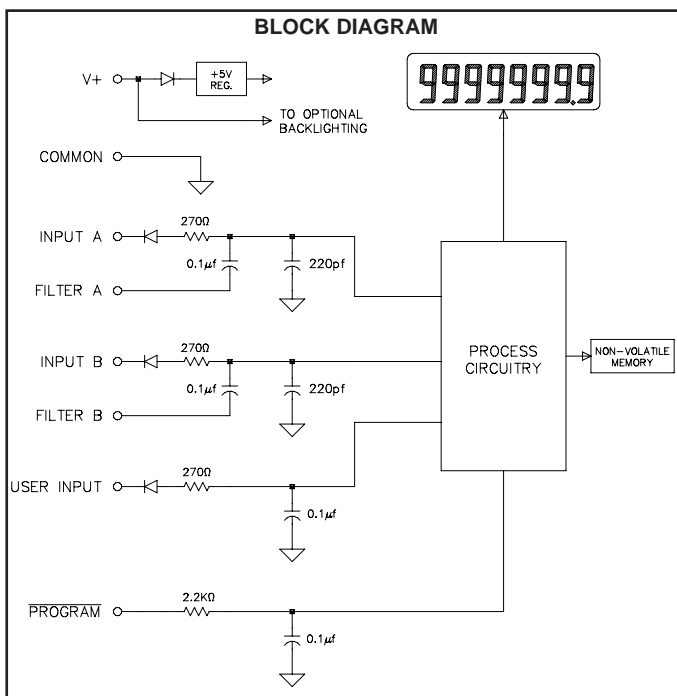

DISPLAY SELECTION

In the normal operating mode the program terminal is not connected to common. The display indicates either:

- Rate value designated by an "R" to the left of the display,
- "A" count value (no designator), or
- "B" count value designated by a "b" to the left of the display

If the Select button is enabled, the display may be toggled by pressing the select button. If display scroll is enabled, the display will toggle automatically approximately every four seconds between the rate and count values. If both the select button and display scroll are enabled, pressing and holding the select button pauses the automatic toggle (if enabled) as long as the select button is held.

PROGRAMMING GENERAL DESCRIPTION

Programming the CUB5 is done with the front panel buttons. Although the unit has been programmed at the factory, the parameters generally have to be changed to meet the user's requirements. To enter the programming mode, connect the program terminal to the common terminal.

Pressing the select button scrolls through the menus. The display alternately flashes between the menu and the currently selected data. Pressing the reset button stops the display from flashing and enters the unit into the data modification mode.

In the data modification mode, a menu has one of two types of parameters to program.

1. **Selection type** - The operator presses the reset button to scroll through the various parameters available for that menu or to toggle between a Yes or No selection. Pressing and holding the Select button exits the data modification mode and advances to the next menu.
2. **Numerical type** - The reset button increments the numerical value of the flashing digit. Momentarily pressing the Select button advances to the next digit. Pressing and holding the Select button for more than two seconds exits the data modification mode and advances to the next menu.

All parameter values are saved when exiting the programming mode. To exit the programming mode, remove the connection between the Program terminal and the Common terminal. If power is removed from the CUB5 prior to exiting the programming mode, the new data is not saved.

PROGRAMMING MENUS

1. COUNT MODES (INP A-b)

There are eight count modes to select from. This selection determines the function of Input A and Input B and assigns the function to either COUNTER A, COUNTER B, RATE INDICATOR or a combination of the three. The user input terminal programmed for the inhibit function, can be used with any of the count modes. Input A is always assigned to the RATE INDICATOR.

Counting with Direction (cnt ud)

Counter A will increment/decrement a count on every negative edge of the input signal at Input A. The direction of the count is determined by the logic state of Input B. A high level at Input B will cause Counter A to increment one count. A low level will cause the unit to decrement a count. The rate display is NOT affected by the logic state of Input B.

Rate Counter (rtE cnt)

Counter A increments one count on every negative edge of the input signal at Input B. The direction of the count is only positive. Input A is used exclusively for the RATE INDICATOR.

Dual Counter (dUAL cnt)

Counter A increments one count on every negative edge of the input signal at Input A. Counter B increments one count on every negative edge of the input signal at Input B.

Note: This is the only mode in which Dual Counting is available.

Quadrature X 1 (QUAd1)

Quadrature counting modes are primarily used in positioning and anti-jitter applications. This mode requires two identical square wave signals with one of them (QUAD) shifted 90° relative to the other (COUNT). These two signals are processed by the CUB5 as follows.

Input A serves as the count and rate input, while Input B serves as the quadrature input. For quadrature with single edge counting, the counter will count in a positive direction when Input A is a negative going edge and Input B is at a low level. The counter will count in a negative direction when Input A is a positive going edge and Input B is at a low level. All transitions on Input A are ignored when Input B is at a high level. These logic rules provide the basis for anti-jitter operation which prevents false counts from occurring due to back-lash, vibration, chatter, etc.

Quadrature X 2 (QUAd2)

When two edge counting is used, the quadrature mode works the same as single edge counting when Input B is low. When Input B is a high level, counts at Input A are no longer ignored. Instead, the logic rules for Input A are complimented, allowing both edges of Input A to be counted. This doubles the effective resolution of the encoded input.

Quadrature X 4 (QUAd4)

This mode takes the quadrature mode with two-edge counting one step further. In quadrature times 4, both Input A and B serve as the count or quadrature input, depending on their state. In one instance, Input A will serve as the count input and Input B will serve as the quadrature input. In another instance, Input A will be the quadrature input and Input B will be the count input. This enables each edge, positive and negative going, of both inputs, A and B, to be counted. This results in a resolution four times greater than in the basic quadrature X1 mode. As in the other modes, Input A is also used for the rate input.

Two Input Anti-Coincidence Add/Add (Add/Add)

This mode effectively sums count pulses that may simultaneously appear on the two inputs. Counter A processes the pulses into a string of time separated pulses so the internal counter will not lose any counts. Input A serves as an add input (count increments) and Input B serves as an additional add input (count increments).

Two Input Anti-Coincidence Add/Subtract (Add/Sub)

This mode effectively separates count pulses that may simultaneously appear at the two inputs. Counter A processes the pulses into a string of time-separated pulses, so the internal counter will not lose any counts. Input A serves as the add input (count increments) and Input B serves as the subtract input (count decrements).

2. SELECT ENABLE (dSPSEL)

The front panel Select button can be enabled (Yes) OR disabled (NO) during normal operation. If "NO" is selected, the display remains either on the rate or count display(s) depending on which was viewed when programming was entered.

3. RESET ENABLE (rSt Enb)

When the count mode INP A-b is not equal to "dUAL cnt", the front panel Reset button can be enabled (Yes) or disabled (No) during programming. The count may not be reset via the front panel if disabled.

When the count mode INP A-b is programmed for "dUAL cnt" the front panel reset button can be enabled to reset:

- (total) Counter A
- (b total) Counter B
- (both) Counters A and B
- (diSPly) Displayed count
- (NONE) None.

If "NONE" is selected, neither counter can be reset from the front panel.

4. COUNTER A DECIMAL POINT (tot dP)

There are six decimal point locations available for the count display. The decimal point locations are used for the count display only and are independent of the rate display.

0
0.0
0.00
0.000
0.0000
0.00000

5. COUNTER A SCALE FACTOR (SCLFAC)

The scale factor is a prescaler, therefore changing the scale factor value does not change the existing internal count, and only effects the incoming pulse count. The Count Scale Factor Value can range from 0.0001 to 99.9999.

Note: The precision of a counter application cannot be improved by using a scale factor greater than one. To accomplish greater precision, more pulse information must be generated per measuring unit.

6. COUNTER B DECIMAL POINT (btot dP) INP A-b = dUAL cnt

There are six decimal point locations available for the count display. The decimal point locations are used for the count display only and are independent of the rate display.

0
0.0
0.00
0.000
0.0000
0.00000

7. COUNTER B SCALE FACTOR

(b SCLFAC) INP A-b = dUAL cnt

The scale factor is a prescaler, therefore changing the scale factor value does not change the existing internal count, and only affects the incoming pulse count. The Count Scale Factor Value can range from 0.0001 to 99.9999.

Note: The precision of a counter application cannot be improved by using a scale factor greater than one. To accomplish greater precision, more pulse information must be generated per measuring unit.

8. RATE ENABLE (rAtE Enb)

Selecting "YES" enables the rate indicator function. If disabled (NO), the rate programming steps will not appear. This affects the rate only.

9. RATE DECIMAL POINT (rAtE dP)

Select the desired decimal point position for the rate display, independent of the count display.

0
0.0
0.00
0.000
0.0000
0.00000

10. RATE DISPLAY(rAtE dSP)

Program the desired rate display value which corresponds to the programmed rate input (rate INP) value. The rate display value can be programmed from 000001 to 999999.

11. RATE INPUT(rAtE INP)

Program the rate input value that should correspond to the rate display (rate dSP) value. The rate input value can be programmed from 00000.1 to 99999.9 and should correspond to the signal input frequency.

12. MINIMUM UPDATE TIME (Lo-Udt)

This is the minimum amount of time between display updates for the rate display. This affects the rate display only. The low update time ranges from 00.1 to 99.9 seconds. To assist in stabilizing an erratic display, increase Lo-Udt for a display averaging effect.

13. MAXIMUM UPDATE TIME (Hi-Udt)

This is the maximum amount of time before the rate display goes to zero. The rate display goes to zero if the time between successive pulses exceeds the high update (Hi-Udt) time. The high update time ranges from 00.1 to 99.9 seconds.

14. DISPLAY SCROLL (dSPScroL)

The unit can be programmed to automatically toggle between the rate display and count displays by selecting "YES". The display time for each display is fixed and is approximately four seconds per display.

15. USER INPUT (USEr INP)

The User Input is activated when the user terminal is connected to common. The function of the User Input can be programmed for one of the following.

Reset (rESET) - A low level resets the count(s) to zero and as long as the input is low, the unit will not process the input signal.

Store/Reset (Stor-rSt) - A low level freezes the display. The internal count(s) are reset to zero and the unit accumulates counts even when the user input is held low. The count value(s) update when the user input goes high.

Store (StorE) - A low level freezes the display and the unit continues to accumulate counts. The count value(s) update when the user input goes high.

Inhibit (INHibIt) - A low level "freezes" the display and the input signal is ignored.

Select Display (dSPSEL) - A low level toggles between the rate display and count display(s).

16. USER INPUT ASSIGNMENT (USEr ASg) -

(INP A-b is "dUAL cnt" and USEr INP not "dSPSEL")

If the CUB5 is programmed for the "dUAL cnt" mode, the User Input may be assigned to:

- (total) "A" Counter
- (b total) "B" Counter
- (both) "A" and "B" Counters

17. FACTORY SETTINGS (FACT SEt)

All of the parameters are restored to the factory default settings when YES is selected and the front panel select button is pressed. The CUB5 displays "LOAD" for several seconds and then returns to programming of INP A-b (Count Mode) parameter. Factory settings for all the programmable values are listed below.

INP A-b	cnt ud
dSPSEL	YES
rSt Enb	YES
tot dP	0
SCLFAC	01.0000
rAtE Enb	YES
rAtE dP	0
rAtE dSP	001000
rAtE INP	01000.0
Lo-Udt	01.0
Hi-Udt	01.0
dSPScrol	No
USEr INP	rESET

SCALING FOR COUNT INDICATION

The CUB5's scale factor is factory set to 1, to provide one count on the display for each pulse that is input to the unit. In many applications, there will not be a one-to-one correspondence between input pulses and display units. Therefore, it is necessary for the CUB5 to scale or multiply the input pulses by a scaling factor to achieve the desired display units (feet, meters, gallons, etc.)

The incoming pulses are multiplied by the count scale factor value and stored in the internal count register which results in the desired count display value. The scale factor is a prescaler, which means changing the scale factor does not change the existing internal count, but only effects the incoming pulse count.

The Count Scale Factor Value can range from 0.0001 to 99.9999. It is important to note that the precision of a counter application cannot be improved by using a scale factor greater than one. To accomplish greater precision, more pulse information must be generated per measuring unit. The following formula is used to calculate the scale factor.

$$\text{Scale Factor} = \frac{\text{Desired Display Units}}{\text{Number of Pulses}} \times \text{Decimal Point Position}$$

WHERE:

Desired Display Units: Count display units acquired after pulses that occurred.

Number of Pulses: Number of pulses required to achieve the desired display units.

Decimal Point Position:

0	=	1
0.0	=	10
0.00	=	100
0.000	=	1000
0.0000	=	10000
0.00000	=	100000

EXAMPLE: The counter display is used to indicate the total number of feet used in a process. It is necessary to know the number of pulses for the desired units to be displayed. The decimal point is selected to show the resolution in hundredths.

$$\text{Scale Factor} = \frac{\text{Desired Display Units}}{\text{Number of Pulses}} \times \text{Decimal Point Position}$$

Given that 128 pulses are equal to 1 foot, display total feet with a one-hundredth resolution.

$$\text{Scale Factor} = \frac{1.00}{128} \times 100$$

$$\text{Scale Factor} = 0.007812 \times 100$$

$$\text{Scale Factor} = 0.7812$$

SCALING FOR RATE INDICATION

Scaling the Rate channel involves programming the CUB5 so that input pulses to the unit are scaled to the desired display units.

Note: It is not necessary to increase the pulse information to obtain higher resolution.

The operator keys-in a display value and a corresponding rate value. The location of the scaling point should be near the process end limit for the best possible accuracy. Once these values are programmed, the indicator calculates the slope of the rate display automatically and scaling is complete after decimal point selection. Input frequency can be read directly if rate display and rate input values are programmed to "1" and "1.0".

Note: The rate display will flash "r OLOLOL" if the display exceeds 999,999, which means the unit must be re-scaled.

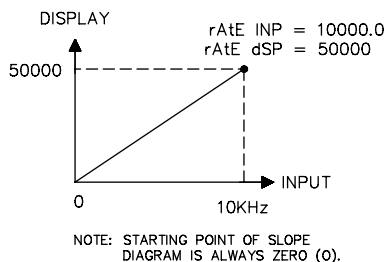

If the rate application is to display a specific display unit, it is only necessary to know the number of pulses per desired display unit/s (feet, revolutions, etc.) and in the desired time format, per second (1), per minute (60), or per hour (3600) to scale the rate display. Use the following formula to calculate the rate input value:

$$\text{rAtE INP (Hz)} = \text{rAtE dSP} \times \frac{\text{pulses per unit}}{\text{desired time format}}$$

WHERE:

- rAtE INP = Rate input value.
- rAtE dSP = Desired rate display value.
- Pulses per unit = Number of actual input pulses.
- Desired time format = 1 if rAtE dSP is to display units per second. 60 if rAtE dSP is to display units per minute. 3600 if rAtE dSP is to display units per hour.

EXAMPLE: Display is to indicate 1575 revolutions per minute (RPM). Input pulses are 39 pulses per revolution.

$$\text{rAtE INP (Hz)} = 1575 \text{ RPM} \times \frac{39 \text{ PPR}}{60}$$

$$\text{rAtE INP (Hz)} = 1023.75$$

Since the rate input value can only be programmed in tenths, the value is recalculated by increasing the rate display value by a factor of ten. The display value is continually increased until one of the following is reached.

1. The rAtE INP value's least significant digit is no smaller than a tenth.
2. The rAtE dSP value exceeds 999,999.
3. The rAtE INP value exceeds 99999.9.

Note: For two and three, use the value that was calculated prior to exceeding that value.

$$\text{rAtE INP (Hz)} = 15750 \text{ RPM} \times \frac{39 \text{ PPR}}{60}$$

$$\text{rAtE INP (Hz)} = 10237.5$$

15750 is entered for the rAtE dSP.

10237.5 is entered for the rAtE INP.

RATE

The rate value calculation uses the time measured between the first and last pulse as the measurement period. The measurement period begins when a negative going edge is received at the signal input A. When the Low Update time has expired, the unit will end the measurement period on the next negative going edge and update the display. The unit will count the number of pulses that occurred during the measurement period and update the display, according to the scaling value, at the end of the measurement period. To assist in stabilizing an erratic display, increase Lo-Udt (Low Update Time) for a display averaging effect. If the unit does not receive a negative edge within the period between the low update and high update time, the unit will end the measurement period and the input (rate) display will go to zero. At very low count rates, the update time (measurement period) will be the actual period of one count cycle.

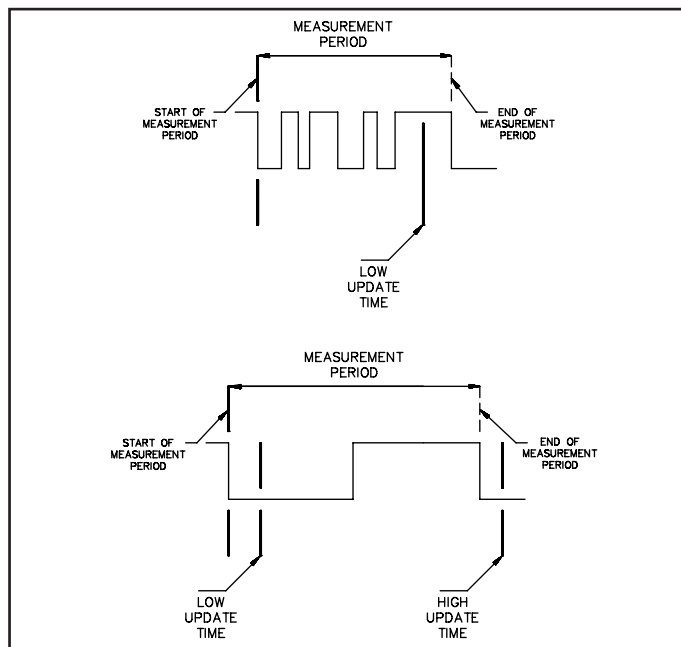

EMC INSTALLATION GUIDELINES

Although this unit is designed with a high degree of immunity to ElectroMagnetic Interference (EMI), proper installation and wiring methods must be followed to ensure compatibility in each application. The type of the electrical noise, source or coupling method into the unit may be different for various installations.

In extremely high EMI environments, additional measures may be needed. The unit becomes more immune to EMI with fewer I/O connections. Cable length, routing and shield termination are very important and can mean the difference between a successful installation or a troublesome installation.

Listed below are some additional EMC guidelines for successful installation in an industrial environment.

1. Use shielded (screened) cables for all Signal and Control inputs. The shield (screen) pigtail connection should be made as short as possible. The connection point for the shield depends somewhat upon the application. Listed below are the recommended methods of connecting the shield, in order of their effectiveness.
 - a. Connect the shield only at the panel where the unit is mounted to earth ground (protective earth).
 - b. Connect the shield to earth ground at both ends of the cable, usually when the noise source frequency is above 1 MHz.
 - c. Connect the shield to common of the unit and leave the other end of the shield unconnected and insulated from earth ground.
2. Never run Signal or Control cables in the same conduit or raceway with AC power lines, conductors feeding motors, solenoids, SCR controls, and heaters, etc. The cables should be run in metal conduit that is properly grounded. This is especially useful in applications where cable runs are long and portable two-way radios are used in close proximity or if the installation is near a commercial radio transmitter.
3. Signal or Control cables within an enclosure should be routed as far away as possible from contactors, control relays, transformers, and other noisy components.
4. In extremely high EMI environments, the use of external EMI suppression devices, such as ferrite suppression cores, is effective. Install them on Signal and Control cables as close to the unit as possible. Loop the cable through the core several times or use multiple cores on each cable for additional protection. Install line filters on the power input cable to the unit to suppress power line interference. Install them near the power entry point of the enclosure. The following EMI suppression devices (or equivalent) are recommended:
 - Ferrite Suppression Cores for signal and control cables:
 - Fair-Rite # 0443167251 (RLC #FCOR0000)
 - TDK # ZCAT3035-1330A
 - Steward #28B2029-0A0
 - Line Filters for input power cables:
 - Schaffner # FN610-1/07 (RLC #LFIL0000)
 - Schaffner # FN670-1.8/07
 - Corcom #1VR3
5. Long cable runs are more susceptible to EMI pickup than short cable runs. Therefore, keep cable runs as short as possible.

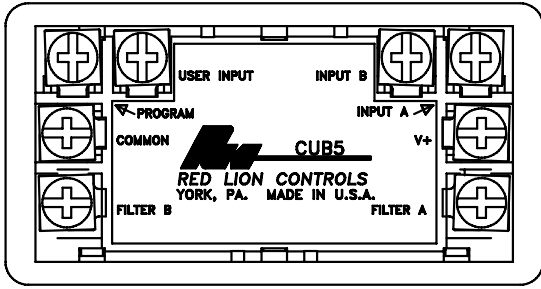

WIRING CONNECTIONS

The electrical connections are made with screw-clamp terminals located on the back of the unit. All conductors should meet voltage and current ratings for each terminal. Also cabling should conform to appropriate standards of good installation, local codes and regulations. It is recommended that power supplied to the unit (AC or DC) be protected by a fuse or circuit breaker. When wiring the unit, use the label to identify the wire position with the proper function. Strip the wire, leaving approximately 1/4" bare wire exposed (strand wire should be tinned with solder). Insert the wire into the screw-clamp terminal and tighten the screw until the wire is clamped tightly. Each terminal can accept up to two # 14 AWG wires.

INSTALLATION ENVIRONMENT

The unit should be installed in a location that does not exceed the maximum operating temperature and provides good air circulation. Placing the unit near devices that generate excessive heat should be avoided.

The bezel should be cleaned only with a soft cloth and neutral soap product.

Do NOT use solvents. Continuous exposure to direct sunlight may accelerate the aging process of the bezel. Do not use tools of any kind (screwdrivers, pens, pencils, etc.) to operate the keypad of the unit.

INSTALLATION

The CUB5 meets NEMA 4X/IP65 requirements for indoor use, when properly installed. The units are intended to be mounted into an enclosed panel. The viewing window and reset button are factory sealed for a wash down environment. A sponge rubber gasket and mounting clip are provided for sealing the unit in the panel cut-out.

The following procedure assures proper installation:

1. Cut panel opening to specified dimensions. Remove burrs and clean around panel opening.
2. Carefully remove the center section of the gasket and discard. Slide the panel gasket over the rear of the unit to the back of the bezel.
3. Assemble nut fastener and mounting screw onto both sides of mounting clip. Tip of screw should not project from hole in mounting clip.
4. Install CUB5 unit through the panel cut-out until front bezel flange contacts the panel-mounted gasket.
5. Slide the mounting clip over the rear of the unit until the mounting clip is against the back of the panel. The mounting clip has latching features which engage into mating features on the CUB5 housing.
6. Alternately tighten each screw to ensure uniform gasket pressure. Visually inspect the front panel gasket. The gasket should be compressed about 75 to 80% of its original thickness (recommended torque is 28 to 36 in-oz.). If not, gradually turn mounting screws to further compress gasket.
7. If gasket is not adequately compressed, and mounting screws can no longer be turned, loosen mounting screws and check that mounting clip is latched as close as possible to panel.

Repeat the procedure for tightening mounting screws.

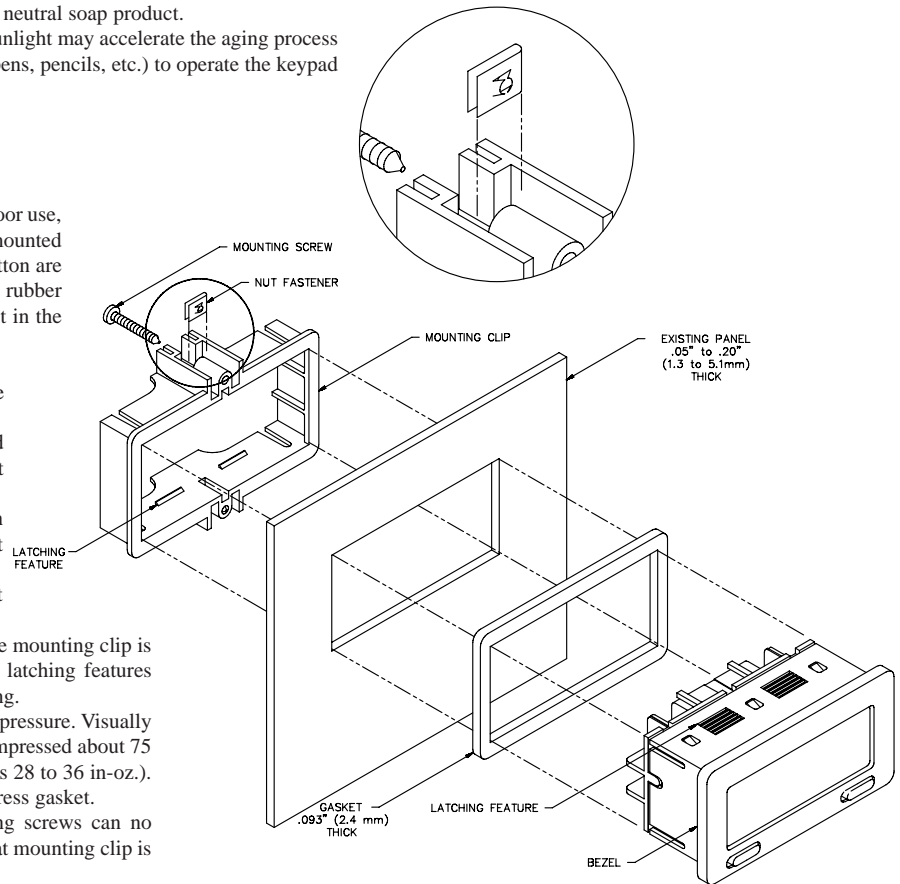

APPLICATION

A dairy producer wishes to indicate the flow rate and record the total gallons of milk dispensed from its processing tank. The CUB5 is installed to meet these requirements.

A PSAC is used to sense a bolt head attached to the shaft of the pump. This results in 32 pulses per gallon dispensed and the counter displays the total gallons in tenths.

The pump typically dispenses 15.0 gallons per minute and the rate display is to indicate tenths of gallons per minute (GPM). The front panel reset button is disabled to prevent unauthorized reset of the total. An external key switch is used for the reset function and the display select button is enabled to allow viewing of either the rate or the total count.

PROGRAMMING:

INP A-b = cnt ud
 dSPSEL = YES
 totrst = NO
 dSPScroL = NO
 USEr INP = rESEt

Count Display Set-up:

tot dP = 0.0
 SCLFAC = $\frac{\text{Desired Display Units}}{\text{Number of Pulses}} \times \text{Decimal Point Position}$
 = $\frac{1.0}{32} \times 10$
 = 0.3125

Rate Display Set-up:

rAtE ENb = YES
 rAtE dP = 0.0
 rAtE dPS = 15.0 GPM
 rAtE INP = rAtE dSP x $\frac{\text{pulses per unit}}{\text{desired time format}}$
 = $15.0 \times \frac{32}{60}$
 = 8.0 Hz
 Lo-Udt = 1.0 sec.
 Hi-Udt = 5.0 sec.

TROUBLESHOOTING

For further technical assistance, contact technical support at the appropriate company numbers listed.

ORDERING INFORMATION

MODEL NO.	DESCRIPTION	PART NUMBERS
CUB5	Dual Counter & Rate Indicator Positive Image Reflective	CUB50000
	Dual Counter & Rate Indicator w/Yel-Grn Backlighting	CUB50010
	Dual Counter & Rate Indicator w/Red Backlighting	CUB50020
MLPS	Micro Line/Sensor Power Supply	MLPS0000

For more information on Pricing, Enclosures & Panel Mount Kits refer to the RLC Catalog or contact your local RLC distributor.

LIMITED WARRANTY

The Company warrants the products it manufactures against defects in materials and workmanship for a period limited to one year from the date of shipment, provided the products have been stored, handled, installed, and used under proper conditions. The Company's liability under this limited warranty shall extend only to the repair or replacement of a defective product, at The Company's option. The Company disclaims all liability for any affirmation, promise or representation with respect to the products.

The customer agrees to hold Red Lion Controls harmless from, defend, and indemnify RLC against damages, claims, and expenses arising out of subsequent sales of RLC products or products containing components manufactured by RLC and based upon personal injuries, deaths, property damage, lost profits, and other matters which Buyer, its employees, or sub-contractors are or may be to any extent liable, including without limitation penalties imposed by the Consumer Product Safety Act (P.L. 92-573) and liability imposed upon any person pursuant to the Magnuson-Moss Warranty Act (P.L. 93-637), as now in effect or as amended hereafter.

No warranties expressed or implied are created with respect to The Company's products except those expressly contained herein. The Customer acknowledges the disclaimers and limitations contained herein and relies on no other warranties or affirmations.